

HOME, PROHIBITION AND EXCISE DEPARTMENT
MOTOR VEHICLES ACTS – ADMINISTRATION
POLICY NOTE 2008 - 09

SL.NO.	SUBJECT
1.	Road Transport- an overview
2.	Organisational set up
3.	Functions of Transport Department
4.	Growth of Vehicles
5.	Revenue Collection
6.	Infrastructure
7.	Improving Service delivery through systems improvement
8.	Interlinking of all offices/Provision of connectivity
9.	Closed Circuit Camera Monitoring system
10.	SMART Card
11.	Setting up of Dedicated LLR Center
12.	Special staff sanctioned for computerization
13.	Road Safety
14.	Specific measures for Road Safety
15.	Mini Bus Scheme
16.	Inter-State Agreement
17.	Air Quality Management Measures
18.	Part II – Schemes 2008-09
19.	Other initiatives
20.	Conclusion
21.	Annexure-I – III Vehicle Population
22.	Annexure- IV – VI Revenue growth
23.	Annexure –VII – VIII Details of Accidents and Fatal accidents
24.	Annexure- IX Details of action taken against drunken driving
25.	Annexure-X Details of action taken against the drivers involved in fatal accidents

I. Road Transport – An overview

1. A good, safe and sustainable transport system is indispensable for the economic growth of the country. The transport department not only endeavours to provide adequate services on the road but also takes care of coordinating, regulating and synchronising of all modes of transport for ensuring smooth and safe travel.

2. The department is committed to providing high quality service to the citizens. The department aims to realize these objectives through adequate enforcement of statutory and non-statutory regulations coupled with modernization and computerization.

II. Organisational set up

3. The transport department is headed by the Transport Commissioner and functions under the administrative control of the Home, Prohibition and Excise department in Government. The Transport Commissioner is also the State Transport Authority and Road Safety Commissioner for Tamil Nadu. In the districts, the respective District Collectors act as the Regional Transport Authorities and in that capacity they dispose of all the matters relating to grant and regulation of transport permits. Appellate and revision powers against the orders of the Regional Transport Authorities and the State Transport Authority lie with the State Transport Appellate Tribunal, Chennai. Presently the state is divided into 7 zones which are further, organized into 53 Regional Transport offices, 45 unit offices and 20 check posts.

III. Functions of Transport Department

4. The Transport Department enforces the provisions of Motor Vehicles Act, 1988, Central Motor Vehicles Rules, 1989, Tamil Nadu Motor Vehicles Rules, 1989, Tamil Nadu Motor Vehicles Taxation Act, 1974 and Tamil Nadu Motor Vehicles Taxation Rules, 1974 and several other related minor Acts and Regulations.

Some of the important functions of the transport department are as follows:

- i. Regulating Road - Transport sector in the state.
- ii. Registration of Vehicles.
- iii. Issue of driving licences, conductor's licences and renewal thereof.
- iv. Grant and regularization of permits, fitness certificates, etc. to Transport vehicles and related functions .
- v. Regulating driving schools and related activities.
- vi. Collection of Vehicle taxes and fees.
- vii. Monitoring and Coordinating Road safety measures.
- viii. Inspection of vehicles involved in accident.
- ix. Drawing up of proposals for Inter State Agreement .
- x. Testing steps to improve air quality.

IV. Growth of Vehicles

5. As regards vehicle population Tamilnadu ranks second in the country, next only to Maharashtra with a total vehicle population of 99.89 lakhs vehicles as of February 2008. In respect of two wheelers the State with a population of 82.05 lakhs as of February 2008 however tops the list in the country. The number and type of vehicles registered and the growth of vehicle population both in Transport and Non-Transport sectors are furnished in Annexures I – III.

V. Revenue Collection

6. The transport department is one of the major revenue earning Departments of the State Government. The total revenue earned by Transport Department during the year 2006-07 was Rs.1272.69 crores. For the financial year 2007-08, Government have fixed a target of Rs.1441 crores against which an amount of Rs.1391.76 crores has already been collected upto February 2008. The total revenue earned by the Department during the past five years through taxes and fees is furnished in Annexures IV -VI. The growth in revenue in 2007-2008 over 2006-07 is likely to be over 18%.

VI. Infrastructure

Zonal Office Buildings

7.1. There are 7 Zonal Offices in the State at Chennai, Villupuram, Salem, Coimbatore, Thiruchirapalli, Madurai and Tirunelveli. Out of these 7 zonal Offices, only the Coimbatore and Tirunelveli zonal offices are functioning in Government buildings. It is proposed to construct buildings for the rest of the Zonal offices in the coming years on a phased manner.

Regional Transport Offices

7.2. Out of 53 Regional Transport Offices in Tamil Nadu, 22 offices are functioning in own buildings. Buildings for ten regional transport offices are presently under construction at an estimated cost of Rs.12.55 Crores.

Unit Offices

7.3. Out of the 45 Unit Offices in Tamil Nadu only one office at Kovilpatti is presently functioning in Government building and five buildings for unit offices are under construction at an estimated cost of Rs.2.75 Crores.

Checkposts

7.4. There are 20 Checkposts of which 19 are functioning on the borders of the adjoining States of Andhra Pradesh, Karnataka, Kerala and Puducherry and one Checkpost at Poonamallee is functioning within the State specially intended to monitor the movement of incoming vehicles from Bangalore (Karnataka) and Chittoor (Andhra Pradesh) via various diversion routes.

Testing Tracks

7.5. To facilitate adequate and proper testing and checking of the 'driving skills of the applicants before issue of licences, provision of scientifically designed testing tracks are essential. Out of 53 Regional Transport Offices and 45 Unit Offices, 25 offices are presently equipped with full-fledged testing tracks and efforts are being made to provide testing tracks in all the other offices in a phased manner. During 2007-08 testing tracks are under construction in 5 Regional Transport Offices and one Unit Office at a cost of Rs.1.35 Crores.

VII. Improving Service delivery through Systems improvement.

Computerisation and Modernisation

8. The presence of a very large number of vehicles and their sustained growth year after year, has necessitated computerization of the operations of the department. Steps in this regard were first initiated during 1999 to computerize some of the functions in Transport Department by creation of a proper database with a twin objective of providing greater transparency and efficient service. Computerization has been taken up in 3 phases. In the first phase 13 Regional transport offices and 3 unit offices were computerized. In its second phase 32 Regional Transport Offices and 8 Unit Offices and in the third and concluding phase remaining 29 unit offices, one Regional Transport Office, 7 Zonal Deputy Transport Commissioner's offices and office of the State Transport Appellate Tribunal, Chennai were covered. This apart, as and when new Regional Transport

Offices and Unit Offices are opened, computerisation of their records is taken up as part of the effort.

9. At present all the services related to the general public such as issue of licences, permits, registration certificates, fitness certificates, tax payment etc., are being implemented through computers using the customized software "Vahan and Sarathi" developed by the National Informatics Center.

10. As of today Tamil Nadu is the only State in India that uses "Vahan and Sarathi" software in all 53 Regional Transport Offices, 45 Unit Offices, 7 Zonal offices, State Transport Authority and State Transport Appellate Tribunal of Transport Department. This has been achieved at a cost of Rs.17.00 crores.

VIII. Interlinking of all Offices/provision of connectivity

11. All Regional Transport Offices and Unit Offices have been provided with broadband facilities and these will be shortly interlinked with National Informatics Centre and State Transport Authority and other user Departments such as Police, State Crime Record Bureau etc., All necessary steps to uplink the data and trial run of integrated data management are currently being processed by National Informatics Centre. In the coming years the department would be interlinked using the Tamil Nadu Wide Area Network System(TNSWAN). A separate allocation of Rs.61.19 lakhs has been made for this.

IX. Closed Circuit Camera Monitoring System

12. In order to monitor the activities within Transport Offices, Rs.10.00 Lakhs have been set apart for provision of Closed circuit camera monitoring system for installation in the Regional Transport Offices of Chennai City Chennai(North) at Vyasarpadi, Chennai (North West) at Annanagar, Chennai (South West) at Valasarawalkam and Meenambakkam on experimental basis.

13. Already closed circuit cameras have been installed in Regional Transport Offices in Chennai(Central), Chennai(East), Chennai(West), Chennai(South) and Office of the State Transport Authority.

X. SMART Card

14. A policy decision has been taken by the Government to introduce the SMART card system to be implemented in 3 Regional Transport Offices namely, Chennai(South), Cuddalore and Sivaganga, on pilot basis. The SMART card type driving license contains two parts, the first part being visual inspection zone and the second part being machine readable zone. The embedded microchip on each smart card can store electronic data and execute commands, which can be read and updated using terminals and devices. Based on the success of the pilot project, this project will be extended to all the Regional Transport Offices/Unit Offices throughout the State in a phased manner. Introduction of the Smart Card system is expected to enhance the efficiency of traffic regulatory activities of both the Transport and Police departments.

XI. Setting up of Dedicated Learner's Licence Centres

15. To minimise the subjectivity in the issue of Learner's Licences and to streamline the process, automation in the issue of Learner's Licences has been introduced on a pilot basis in three Regional Transport Offices in Chennai City i.e. at RTOs, Chennai (West) at K.K. Nagar and Chennai (North West) at Anna Nagar and Meenambakkam under the e-governance project funded by the Government of India. Under this scheme, a separate learner's licence centre with sufficient space and 5/10 computer terminals have been provided and online tests are being conducted for issue of learner's licences. As a result the licences are issued immediately upon completion of the test on the spot. For the convenience of the public, the timings fixed for granting learner's licence have also been extended upto 4.00 P.M. as against 11.00 A.M. on all working days. Based on the success of this project the Government have proposed to extend this program to 35 more

Regional Transport Offices /Unit Offices throughout the State with funding under the Central Government's e-Governance project.

XII. Special Staff for computerization

16. Government have sanctioned 93 posts of Programmers and 4 System Analysts initially for a period of three years from 01/4/2007 to be appointed on contract basis (at a cost of Rs.82.22 lakhs annually) in the Transport Department for computerization. Presently all Regional Transport Offices / Unit Offices of this Department have been provided with one programmer each to facilitate smooth functioning of the computerization activities.

XIII. Road Safety

17. Ensuring road safety is one of the priority areas receiving Government's constant attention. Tamil Nadu is the first state in the country to have brought out a road safety policy. This policy has been brought out with a vision to stop and reverse the increasing trend in the number of accidents, number of deaths, number of injuries through adoption of comprehensive measures covering engineering, education, health, emergency care and enforcement measures. The road safety policy seeks to achieve 20% reduction in fatalities and injuries in road accidents by 2013 considering 2006 as the base year.

18. To translate the objectives of road safety policy into reality the Government have taken steps to create necessary institutional arrangements. A high level body 'State Road Safety Council' has been constituted under the Chairmanship of Honourable Minister for Transport, to advise the Government on all policies and programmes relating to road safety at the State level. This council reviews the implementation of various programmes of different departments and suggests policy initiatives to Government. Government have also established the District Road Safety Councils functioning in each District under the Chairmanship of the District Collectors. This council has been entrusted with the job of considering various measures needed to promote road safety, prepare road safety plans with special attention to the accident prone spots/stretchers, maintenance of roads, drivers training, accident analysis, publicity initiatives and efforts, traffic planning, highway patrol, passenger amenities etc. in the Districts. These councils are required to meet at least once in a month.

Apart from these State level and district level institutions the State road safety commissionerate also takes up the following activities:-

- ❖ Sending proposals to the Government on Road Safety Policies to be implemented in the State;
- ❖ Overseeing the functioning of the District Road Safety Councils;
- ❖ Reviewing the data relating to road accidents, taking up the case studies and identifying causes and remedial measures to avert accidents;
- ❖ Suggesting and recommending specific schemes for financial assistance under Road Safety Fund to the Districts and various other agencies including Non- Government Organizations engaged in the task;
- ❖ Expediting relief operations and post- accident remedial measures so that the victims could be timely and suitably assisted;
- ❖ Controlling the vehicular pollution by involving the Tamilnadu Pollution Control Board, Police and other Agencies.

19. The Government have constituted "The Road Safety Fund" from out of the receipts of compounding fees and spot fines collected by transport/police departments to finance road safety activities. The Road Safety Fund is administered by an Inter-Departmental Committee headed by the Home Secretary. The allocations made to this fund stood at Rs.3.75 crores in 2001-

2002, raised to Rs.5.00 crores in 2002-2003 and to Rs.6.00 crores in 2005-2006. The allocation for the fund in 2008-2009 has been further increased to Rs.10 crores.

XIV. Specific Measures for Road Safety

20. To prevent road accidents and to save precious lives involved in the accidents the strategy of the Government on road safety measures is focussed mainly on three major thrust areas. i.e.

- (i) Preventive measures;
- (ii) Surveillance and detection; and
- (iii) Enforcement measures.

20.1. Preventive Measures:

(i) Making Fastening of seat belts compulsory:

The Government have ordered the 'wearing of seat belts' by the driver, the person occupying the front seat, and the person seated in the front facing rear seats of the motor vehicle while in motion as compulsory.

(ii) Making wearing of helmets compulsory:

Government have also made the 'wearing of helmets compulsory for all the two-wheeler drivers and pillion riders. Subsequently on representation from the public, Government have exempted members of the Meivazhi Sabha, women pillion riders, and children pillion riders from compulsory wearing of helmets.

(iii) Prohibition of Black films on wind screen front glass and rear windows:

In accordance with the existing provisions of Rule 100(2) of Central Motor Vehicles Rules 1989 use of black films in the wind screen glass and rear window of the vehicle is prohibited.

(iv) Road Safety Week:

Every year, in the first week of January, Road Safety Week is celebrated throughout the State so as to create adequate awareness among School/ College students, drivers and all other road users. During the year 2007-2008 Rs.65 lakhs was provided for Road Safety awareness building programmes. Apart from this, workshops for drivers involved in road accidents are also conducted as a measure to sensitize them and to create greater awareness regarding road safety aspects.

(v) Holistic approach to study and prevent Fatal accidents:

In order to analyse every case of fatal accidents taking place in this State an Inter-Departmental team of officers comprising Police, Transport and Highways departments has been constituted. This Inter-departmental team will visit the accident spot on the same or at the most the very next day, make a comprehensive study from different angles, prepare a detailed report after critically analyzing the data and offer specific information and suggest suitable measures, preventive remedial and punitive that may have to be initiated to avert such incidents in future. This newly set up information system is expected to provide useful inputs for policy initiatives by Government.

(vi) Special initiatives to ensure greater safety of School children/College students:

Government consider safety of school children and college students as an important aspect of Road Safety. To address the issue holistically, Government on one hand have prescribed separate/specific colour i.e. Sky-Blue for Educational Institutional Buses, in order to differentiate the Educational Institutional Buses from other Motor Vehicles so as to alert the drivers of other vehicles to drive carefully and more cautiously. The Government have also prescribed certain specific regulatory measures to ensure quality of drivers, fitness of vehicles, speed etc.,

20.2. Surveillance and Detection:

Emergency Accident Relief Centres: (EARC)

Considering the phenomenal increase in vehicular population contributing to increase in road accidents, 100 Emergency Accident Relief Centres have been established on all the important National and State Highways, to give first aid to the accident victims within the "golden hour" and to arrange for further treatment through the nearby referral hospitals. Each centre has an ambulance to respond to the accident cases with essential drugs, paramedical staff and driver available round the clock making it convenient for public to access these centres through a toll free Phone number of 1073. Out of the 100 centres presently functioning, 64 centres are fully sponsored by private hospitals, institutions and non-government organisations and 36 centres are partially funded by them with the balance financial assistance from Government. The Government assistance is upto a maximum of Rs.40,000/- per month per centre. An amount of Rs.1.73 crores has been allotted for running these 36 partially sponsored Emergency Accident Relief Centres and due to the timely assistance rendered by these emergency accident relief centres, so far 8127 lives have been saved from fatalities during the year 2007-2008 upto February 2008. Statements showing the details of accidents, fatal details are at Annexures VII - VIII.

20.3. Enforcement Measures:

Deterrent Punitive action:

Government believes in strict enforcement of Law and deals with offenders sternly. Besides launching of criminal prosecution against drivers involved in major and fatal accidents, the licences of such drivers are suspended for a period of not less than six months in the first instance and cancelled in the cases of subsequent offences. The details relating to the number of driving licences suspended and cancelled are furnished in Annexures IX and X.

Compensation to Road Accident Victims:

21. The Motor Vehicles Act, 1988 provides for payment of compensation to the victims of road accidents with reference to their age, earning capacity, cause of the accident etc. The Act also provides for a minimum amount of compensation irrespective of the fact as to who was at fault. These claims are settled by the Motor Vehicles Accident Claims Tribunals established throughout the State. In addition under Chief Minister's Accident Relief Fund an ex-gratia payment is also allowed for the road accident victims and their legal heirs at the following scale:-

Sl. No	Nature of Loss	Compensation (in Rs)
1	Death	10,000
2	Total disability	6,000
3	Loss of one eye or one limb	4,000
4	Other cases	500

An amount of Rs. 5 crores has been provided during 2008-09 for this purpose.

22. Beside, ex-gratia payments are also sanctioned to the victims and bereaved persons involved in the road accidents travelling in buses belonging to State Transport Undertakings from the Chief Ministers Public Relief Fund. To enable the victims family to get this relief quickly powers have since been delegated to the respective District Collectors. This apart exgratia payments are also being made to the families of the dead and to the injured involved in very serious and major road accidents from out of the Chief Minister's Public Relief Fund.

XV. Mini Bus Scheme

23. Recognising the need to provide public transport facilities to the people of unserved or inadequately served, semi-urban and rural areas, the Government introduced the Mini-bus

services scheme operated by private individuals first during 1997. In spite of the fact that this scheme was challenged by some of the private operators in the Court of Law, considering the benefits of this scheme, Government in the year 1999 modified this scheme enabling operations of Mini Buses in the rural areas for a total distance of 20 kms, with an overlapping distance of 4 kms on the served sectors. This modified scheme has also been challenged before the Court of Law and Government are taking appropriate steps to have the matter sorted out. Presently 3961 mini buses are plying in the state of Tamilnadu. The Government are also exploring the possibility of bringing out a "New Mini Bus Policy" by formulating a State-wide comprehensive Area Scheme.

XVI Inter-State Agreements

24.1. To facilitate free flow of passenger and goods traffic among neighbouring States Inter-State agreements are arrived at either on single point tax or on concessional rates on reciprocal basis. This agreement enables operation of goods and passenger services between two agreeing states for unhindered movement of a specified number of goods carriages, contract carriages and stage carriages. Tamilnadu State though had entered into agreements with the neighbouring States of Karnataka, Andhra Pradesh, Kerala and Puducherry, these were not renewed, updated and finalised between the neighbouring States viz. Andhra Pradesh, Kerala, Karnataka and Puducherry for the past 10 years. In order to provide additional transport facilities and also to connect the important commercial business centres and the centres of tourist attraction throughout the Southern States, new routes have been formulated by entering into supplemental Inter-State Agreements with the neighbouring States as below:-

- (i) It has been approved to operate between Tamil Nadu and Karnataka 315 new buses of Tamil Nadu and 300 new buses by Karnataka, covering service kilometre of 1.25 lakhs Kms. This is in addition to the existing 198 routes servicing 85,476 kms.
- (ii) It has been finalized to operate between Tamil Nadu and Andhra Pradesh 123 new buses by Tamil Nadu and 140 new buses by Andhra Pradesh, covering service kilometre of about 46,000 Kms. This is in addition to the existing 141 routes servicing 56,709 kms.
- (iii) Similarly, It has also been finalized to operate 39 new buses between Tamil Nadu and Kerala by Tamil Nadu and 45 new buses by Kerala State Transport Undertaking, covering a service kilometre of about 12,000 Kms. This is in addition to the existing 231 routes servicing 72,367 kms.
- (iv) In respect of Tamil Nadu and Puducherry Government have arranged for conducting Inter-State meeting. Finalisation of the agreement is in process.

24.2. Goods Carriage Permits:

Based on the agreement made to increase the quota of Goods Carriage Permits, it has been decided to enhance the limit from 7500 to 15,000 in respect of Tamil Nadu and Karnataka, from 5400 to 10,000 in respect of Tamil Nadu and Andhra Pradesh, from 3000 to 8000 in respect of Tamil Nadu vehicles plying to Puducherry and from 300 to 800 in respect of Puducherry vehicles plying to Tamil Nadu. The quota of 10,000 permits fixed between Tamil Nadu and Kerala still continues, unaltered.

24.3. Motor Cabs:

In respect of TamilNadu and Karnataka States, it has been agreed to maintain the existing quota of 5000 permits for each state to be countersigned. In respect of TamilNadu and Andhra Pradesh State, the category of Ordinary Taxi cabs and Tourist cabs has been merged in to one category as Motor Cab and the earlier quota of 400 has been increased to 1000 for each State.

24.4. As regards the State of TamilNadu and Kerala, as per the Inter-State Agreement 1999, each State can countersign permits of 600 Tourist Taxi's and 350 ordinary Taxis. In the ensuing agreement the above two categories are merged into one expression, 'motor cab". In respect of TamilNadu and Puducherry, there shall be no limit to the number of permits to be countersigned by each State in respect of Motor Cabs and Tourist Taxis.

XVII. Air Quality Management Measures

25. With the rapid increase in the number of vehicles, the problem of automobile pollution has assumed greater significance. Since the emission of smoke from Motor Vehicles is a major source of air pollution, specific standards for the permissible limits for such emission have been prescribed in the Motor Vehicles Act 1988 and rules made there under- Rule 115 of Central Motor Vehicles Rules 1989 also specifies that all the vehicles which are over one year of age should undergo emission tests for every six months. The Government have authorized 235 Private Emission Testing Centres throughout Tamil Nadu as per rule 116(R) of Tamil Nadu Motor Vehicles Rules 1989 and have made it mandatory that at the time of every transaction with Regional Transport Offices, certificate of Pollution Under Control will be checked.

Certain other measures in this regard include –

- Prescription of a time schedule for petrol driven Autorickshaws in Chennai city to get converted into Liquefied Petroleum Gas (LPG) mode. Tamilnadu Pollution Control Board has also agreed to offer a subsidy of Rs.2000/- per liquefied petroleum gas (LPG) auto as a measure of encouragement for switching over from Petrol autorickshaws to liquefied petroleum gas (LPG) mode.
- Banning of new petrol and diesel auto rickshaw permits.
- Taking up with the Insurance Regulatory and Development Authority seeking their intervention to make 'Pollution Under Control' (PUC) certificates as a mandatory precondition for renewal of vehicle insurance so as to ensure that all vehicles are brought under the purview of pollution norms as a matter of routine.

LPG Auto Permits

26. The Government in relaxation of the ban for issue of Auto permits in Chennai City have granted 10,000 Liquefied Petroleum Gas (LPG) dedicated Autorickshaw permits (5000 with subsidy and 5000 without subsidy). This on one hand is intended to uplift the educated unemployed youth of Chennai city and also to support the cause of environment on the other. So far 4495 proceedings have been issued for grant of permits under non-subsidy scheme and 811 proceedings have been issued under subsidy scheme for the grant of Autorickshaw Permits.

XVIII. Part II – Schemes 2008-09

27. The following new schemes are proposed to be implemented in the year 2008-09.

- (i) Provision of new Jeeps and Cars for Transport Department
10 old Jeeps and 1 old Car will be replaced by 10 new Bolero jeeps and 1 Car for the Regional Transport Officers and Deputy Transport Commissioner, Tirunelveli. Moreover, 3 Jeeps and two new cars will be provided for the use of the officers in the State Transport Authority, Chennai. These vehicles will be provided at a total cost of Rs.88.50 Lakhs .
- (ii) Provision of 8 Fax Machines for Unit Offices / State Transport Appellate Tribunal at a cost of Rs.1.76 lakhs.
- (iii) Provision of Computers and Printers for State Transport Authority at a cost of Rs. 12.70 lakhs

(iv) Provision of Steel Almirahs for State Transport Authority at a cost of Rs.1.70 lakhs

XIX. Other initiatives

28.1. Free Supply of various application and other forms:

In-order to supply to the public free of cost, 10 types of application and other forms under the Motor Vehicles Act 1988 have been printed and supplied to all the Regional Transport Offices and Unit Offices after a gap of several years.

28.2. Improving Quality of drivers and Driving Schools:

Driving Schools run by Individuals/Others are regulated by certain statutory provisions under Motor Vehicles Act 1988 and Central Motor Vehicles Rules, 1989. As there were several missing links in the system, it was felt imperative to review the existing arrangements and bring in place proper and adequate stipulations and guidelines so as to ensure production of quality and skillful drivers, keeping in view the transport, traffic, vehicular strength, rights of various road users and all aspects connected with road safety. Accordingly comprehensive guidelines have been framed and issued. The following are salient features of the guidelines issued:

- The premises of the Driving Schools should have adequate space including the parking space for the vehicles ;
- Driving Schools shall own a minimum of one vehicle of latest model (not older than 8 years at any point of time) in each category;
- Text books each on automobile mechanism, driving, road safety, traffic regulation, first aid, basic law, Rules and regulations governing motor and road transport both in English and Tamil in simple language shall be provided besides Text books on Motor Vehicles Act and the Rules.
- The Driving Schools should impart training to the learners of two wheelers with helmet on and sensitize the candidates learning four wheelers on wearing of seat belts /other road safety measures .
- To cater to the increasing needs of drivers, various Engineering Colleges, Polytechnics and other institutions in the State are being encouraged to establish and operate driving schools, so as to produce more skillful drivers. Candidates are being tested and issued with licenses by testing their Driving skills using these testing tracks.

XX. Conclusion

29. The Transport department is aware of the changing scenario due to rapid growth and increase in the population of vehicles and therefore a duty is cast upon it to give the general public most efficient, effective and transparent services with full and complete safety and to inculcate a sense of safe use of road by all categories of road users, especially in the context of enormous growth of vehicular population. The Transport Department is therefore geared up to meet the challenges of the growing needs and responsibilities with utmost commitment and sincerity.

K.N. NEHRU
MINISTER FOR TRANSPORT

ANNEXURE-I
Details of vehicle Population

[See para 5]

Financial Year	Transport Vehicles	Non-Transport Vehicles		Total Vehicles	Rate of increase in vehicles (Percentage)
		Two Wheelers	Others		
1	2	3	4	5	6
2001-02	4,32,106	46,00,565	6,25,426	56,58,097	9.61
2002-03	4,57,448	50,73,643	6,77,946	62,09,037	9.74
2003-04	4,72,172	55,47,755	7,32,546	67,52,473	8.75
2004-05	4,93,926	61,06,057	8,03,761	74,03,744	9.64
2005-06	5,81,106	67,50,328	8,90,296	82,21,730	11.05
2006-07	6,08,325	75,03,426	9,91,869	91,03,620	10.73
2007-08 (upto 29/02/08)	6,90,473	82,04,528	10,93,867	99,88,868	

ANNEXURE-II

Growth in Vehicle Population

[see para 5]

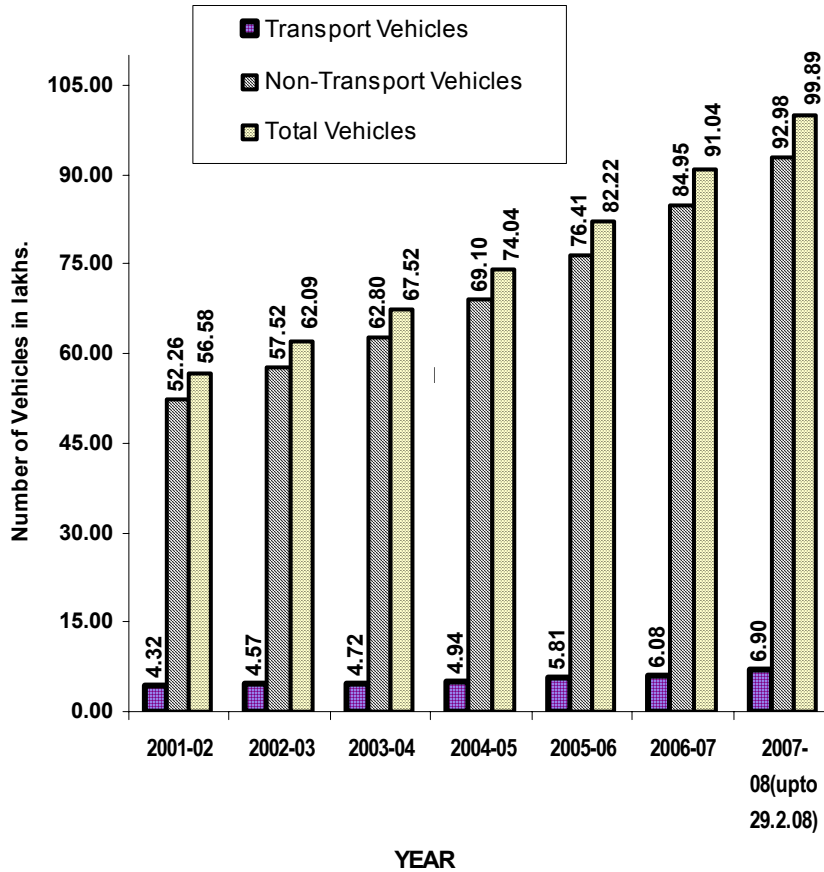

ANNEXURE-III

[see para 5]

Vehicular Position in Tamil Nadu as on 29/2/2008 is given below:-

TRANSPORT		NON TRANSPORT	
STAGE CARRIAGES		TWO WHEELERS	
PUBLIC (STU)	17,874	Motor Cycle	37,97,161
PRIVATE	6,899	Scooter	11,96,800
Total	24,773	Mopeds	32,10,567
Mini bus	4,002	Total	82,04,528
CONTRACT CARRIAGES			
Autorickshaw	1,44,192	Motor Car	8,23,427
Ordinary Taxi	2,367	Jeep	42,110
Motor Cab(SP)	56,442	Tricycle Auto	4,259
Motor Cab(AIP)	8,881	Station Wagon	2,775
Maxi Cab(SP)	32,865	Tractor	1,22,958

Maxi Cab(AIP)	1,676	Three Wheeler	57,683
Omni Bus (SP)	423	Four Wheeler	14,567
Omni Bus (AIP)	130	Road Roller	1,628
Total	2,46,976	Others	24,460
OTHERS			
Private Service Vehicles	7,903		
School Bus	10,743		
Ambulance	4,104		
Fire Fighter	1,558		
Total	24,308		
GOODS CARRIAGES			
Lorries	1,58,404		
National Permit Lorries	38,966		
Tractor & Trailor	61,788		
Light Commercial Vehicles	1,25,980		
Articulated Vehicles	5,276		
Total	3,90,414		
Transport Total	6,90,473	Non Transport Total	92,98,395
STATE TOTAL			99,88,868

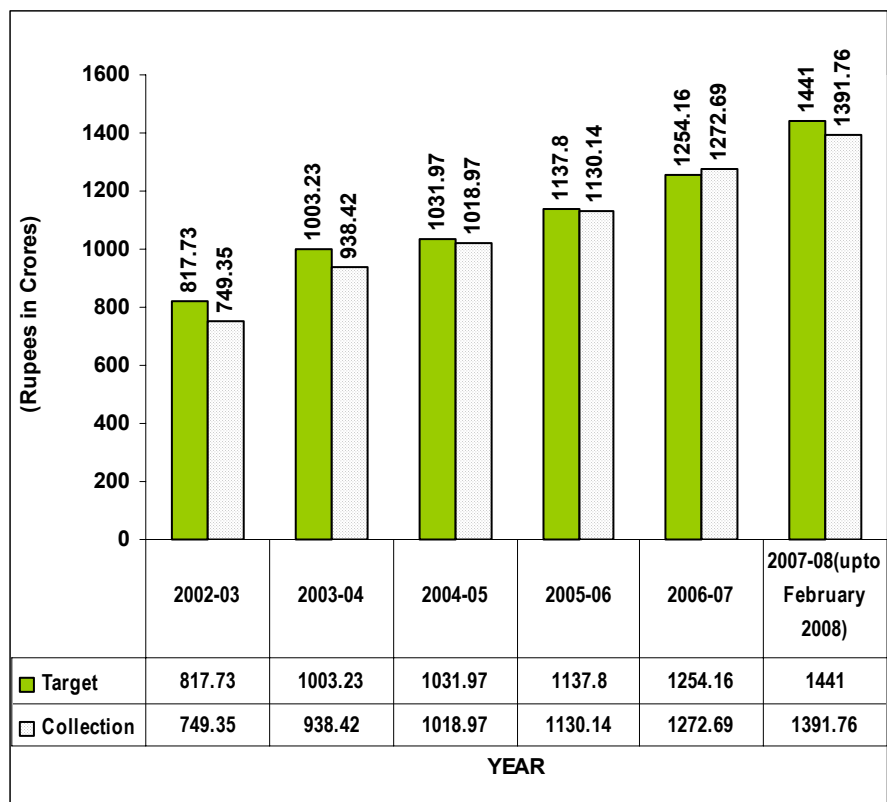

ANNEXURE -IV

(1) Revenue Growth

(Rs. in Crores)

[see para 6]

Financial year	Target for the year	Collection of Motor vehicles tax and fees	% of Achievement	% of growth based on previous years
2002-03	817.73	749.35	91.18%	14.51%
2003-04	1003.23	938.42	93.54%	25.86%
2004-05	1031.97	1018.97	98.74%	8.58%
2005-06	1137.80	1130.14	99.33%	10.91%
2006-07	1254.16	1272.69	101.47%	12.61%
2007-08	1441.00	1391.76 (Collection upto February 2008)		

ANNEXURE –V
(2) Revenue Growth

[see para 6]

ANNEXURE- VI
Headwise collection of
Revenue for the year

2007-08

(Collection upto February 2008)

(Rs. in Crores)

[see para 6]

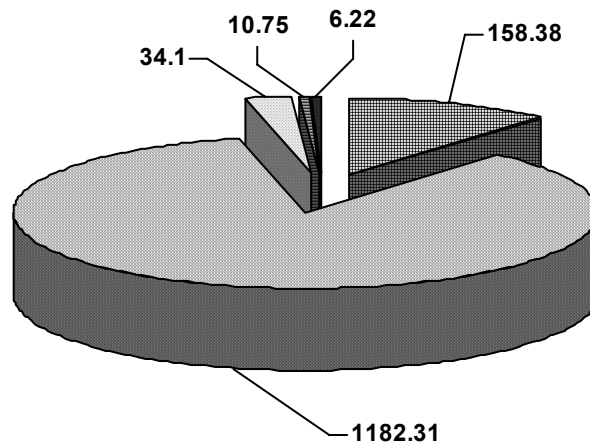

■ Fees ■ Tax ■ Other Receipts ■ Service Charge ■ Misc

ANNEXURE-VII

Details of Fatal Accidents in Tamil Nadu

[see para 20.2]

Calender Year	Total Accidents	Fatal Accidents	No. of persons dead
2002	53503	9012	9939
2003	51025	8393	9275
2004	52508	8733	9507
2005	51152	8358	9215
2006	55145	10055	11009
2007	59140	11034	12036

ANNEXURE- VIII

Comparative Statement of Total Accidents with Fatal Accidents

[see para 20.2]

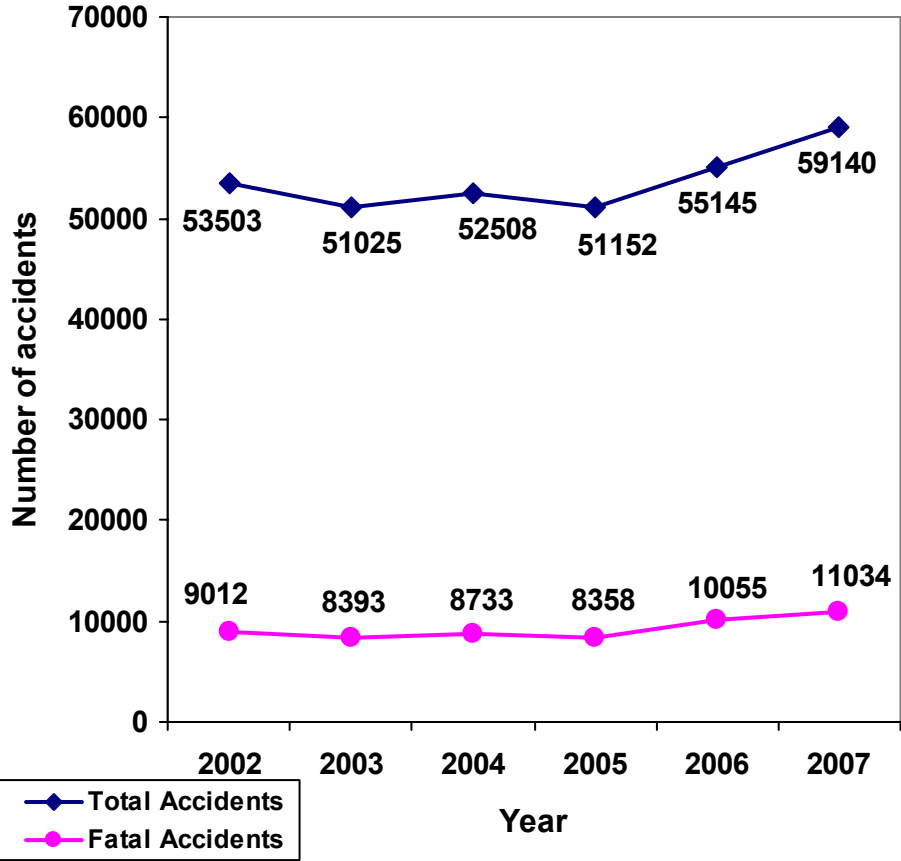

ANNEXURE-IX

Action against the drunken driving for the period from (April 2007 To February 2008)

[see para 20.3]

Driving Licences Suspended	Driving Licences Cancelled
7505	5328

ANNEXURE -X

Action against the drivers involved in fatal accidents for the period from (April 2007 to February 2008)

[see para 20.3]

Driving Licences Suspended	Driving Licences Cancelled
9165	531